

Weldcraft™ W-250 Series Hand-Held Water-Cooled TIG Welding Torches

Formerly WP-20 Series



Quick Specs	Models W-250 W-250 Valve	Applications Aerospace Dairy Food/beverage industry Light and heavy manufacturing Maintenance and repair	Rated Output DC: 250 A, AC: 180 A
		Petro/chemical Precision fabrication Shipbuilding Tube and pipe Vocational	Duty Cycle 100% Electrode Range .020–1/8 in. (0.5–3.2 mm)



W-250 Series TIG torches

Formerly known as the WP-20 Series, the W-250 Series water-cooled torches provide consistent performance and long-term trouble-free service with around-the-head water cooling.

Extend torch life and minimize downtime due to overheating with the efficient around-the-head cooling design.

Comfort and control are increased with the lightweight, compact body design.

Reduce leakage of gas and water through secure mechanical fittings and connections.

Easy hose replacement with the innovative mechanical fittings design (W-250 Valve).

Note: Torches delivered may vary slightly from images shown.

W-250 (WP-20)

W-250 Valve (WP-20V)



Miller Electric Mfg. Co.
An ITW Welding Company
1635 West Spencer Street
P.O. Box 1079
Appleton, WI 54912-1079 USA

Equipment Sales US and Canada
Phone: 866-931-9730
FAX: 800-637-2315
International Phone: 920-735-4554
International FAX: 920-735-4125

MillerWelds.com
f t y i n



Torch Packages

Models		Braided Rubber		Vinyl	
Old Model	New Name	12.5 ft. (3.8 m)	25 ft. (7.6 m)	12.5 ft. (3.8 m)	25 ft. (7.6 m)
WP-20	W-250	WP-20-12-R	WP-20-25-R	WP-20-12	WP-20-25
WP-20V	W-250 Valve	—	—	WP-20V-12	WP-20V-25

V = Valve

Torch packages include torch body, handle, power cable, long back cap, gas hose, and water hose.

Connectors

Power cable connectors



195380
50 mm Dinse-style gas thru with gas and water return lines for water-cooled torch.



195377
50 mm Dinse-style with water return line for water-cooled torch.



45V11
Power cable adapter for water-cooled torch.



225028
50 mm thread-lock-style for water-cooled torch.

Machines	Connection Type	1-Piece Power Cable Connectors
TIG Machines		
Syncrowave® 200/210	50 mm Dinse-style gas thru	195380
Syncrowave® 250 DX/350 DX (Dinse)	50 mm Dinse-style	195377
Syncrowave® 250 DX/350 DX (stud)	1/2 in. stud	45V11
Dynasty® 200/210/280/350, Maxstar® 200/210/280/350	50 mm Dinse-style	195377
Dynasty® 700, Maxstar® 700	50 mm thread-lock	225028
Multiprocess Machines		
Dimension™ 302/452/NT 450/652	1/2 in. stud	45V11
PipeWorx	1/2 in. stud	45V11
XMT® 304/350	50 mm Dinse-style	195377
XMT® 450	1/2 in. stud	45V11
Engine-Driven Machines		
Most Big Blue®, Trailblazer®, Bobcat™, Blue Star® and Wildcat® models	1/2 in. stud	45V11
Big Blue® 450 Duo CST	50 mm Dinse-style	195377
General Reference		
	50 mm Dinse-style	195377
	50 mm Dinse-style gas thru	195380
	50 mm thread-lock	225028
	1/2 in. stud	45V11
Other Adapter		
	Stud to Dinse-style adapter	232728

Consumables (Refer to Owner's Manual for additional replacement parts.)

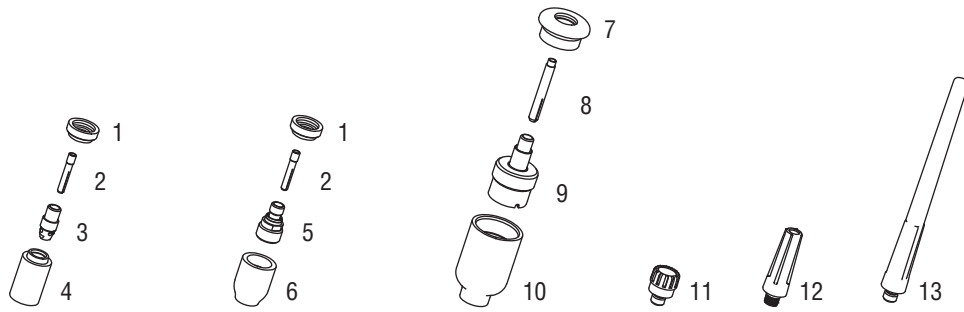

Non-Gas Lens

Electrode Size — inch (mm)	.020 (0.5)	.040 (1.0)	1/16 (1.6)	3/32 (2.4)	1/8 (3.2)				
1 Insulator (required)	598882	598882	598882	598882	598882				
2 Collet	13N20	13N21	13N22	13N23	13N24				
3 Collet Body	13N25	13N26	13N27	13N28	13N29				
Nozzle Size — size # (inch)	3 (3/16)	4 (1/4)	5 (5/16)	6 (3/8)	7 (7/16)	8 (1/2)	10 (5/8)	12 (3/4)	Short
4 Alumina	—	13N08	13N09	13N10	13N11	13N12	13N13	—	—
* Lava	—	13N14	13N15	13N16	13N17	13N18	13N19	—	—
* Long Lava	796F70	796F71	796F72	796F73	—	—	—	—	—
* X-Long Lava	796F74	796F75	796F76	796F77	—	—	—	—	—

Gas Lens

Electrode Size — inch (mm)	.020 (0.5)	.040 (1.0)	1/16 (1.6)	3/32 (2.4)	1/8 (3.2)				
1 Insulator (required)	598882	598882	598882	598882	598882				
2 Collet	13N20	13N21	13N22	13N23	13N24				
5 Gas Lens	45V41	45V42	45V43	45V44	45V45				
Nozzle Size — size # (inch)	3 (3/16)	4 (1/4)	5 (5/16)	6 (3/8)	7 (7/16)	8 (1/2)	10 (5/8)	12 (3/4)	Short
6 Alumina Gas Lens	—	53N58	53N59	53N60	53N61	53N61S	—	—	—

Large Diameter Gas Lens

Electrode Size — inch (mm)	.020 (0.5)	.040 (1.0)	1/16 (1.6)	3/32 (2.4)	1/8 (3.2)				
7 Insulator (required)	54N63-20	54N63-20	54N63-20	54N63-20	54N63-20				
8 Collet	13N20L	13N21L	13N22L	13N23L	13N24L				
9 Large Diameter Gas Lens	45V0204S	45V0204S	45V116S	45V64S	995795S				
Nozzle Size — size # (inch)	3 (3/16)	4 (1/4)	5 (5/16)	6 (3/8)	7 (7/16)	8 (1/2)	10 (5/8)	12 (3/4)	Short
10 Large Dia. Gas Lens	—	—	—	57N75	—	57N74	53N88	53N87	53N89
* Large Dia. Gas Lens-L	—	—	—	57N75L	—	57N74L	53N88L	53N87L	—
* Large Dia. Gas Lens-XL	—	—	—	57N75XL	—	57N74XL	53N88XL	53N87XL	—
* Large Dia. Gas Lens-XXL	—	—	—	57N75XXL	—	57N74XXL	53N88XXL	53N87XXL	—

Back Caps

11 Short 41V33 12 Medium 41V35 13 Long 41V24 * Back cap insulator 9-4

*Not shown.

Tungsten

Tungsten for the most demanding TIG welding applications!

Available in four types and industry-standard diameters, our line of Weldcraft™ tungsten electrodes has undergone rigorous testing to ensure the highest quality and durability. Color-coded packages include ten 7-inch (175 mm) tungsten electrodes.

Note: Refer to manufacturer SDS sheets for proper preparation and safety. Use proper ventilation/capture during preparation. Refer to manufacturer warning regarding ventilation.



Type	Diameter in. (mm)	Part #	Type	Diameter in. (mm)	Part #
2% Ceriated (EWCe-2)			Pure (EWP)		
Performs well in DC welding and arc starting at low-current settings, and offers excellent performance in AC processes.	0.040 (1.0)	WC040X7	Forms a clean, balled end when heated and provides good arc stability for AC welding with a balanced or unbalanced squarewave or sine wave.	0.040 (1.0)	—
	1/16 (1.6)	WC116X7		1/16 (1.6)	WP116X7
	3/32 (2.4)	WC332X7		3/32 (2.4)	WP332X7
	1/8 (3.2)	WC018X7		1/8 (3.2)	WP018X7
	5/32 (4.0)	WC532X7		5/32 (4.0)	—
2% Lanthanated (EWLa-2)			Rare Earth (EWG)		
Provides excellent arc starting, arc stability and re-ignition, and less tip erosion in AC or DC welding. Can substitute for 2% Thoriated.	0.040 (1.0)	WL2040X7	Combines the best of all alloying elements, and provides excellent arc stability in AC or DC welding.	0.040 (1.0)	—
	1/16 (1.6)	WL2116X7		1/16 (1.6)	WG116X7
	3/32 (2.4)	WL2332X7		3/32 (2.4)	WG332X7
	1/8 (3.2)	WL2018X7		1/8 (3.2)	WG018X7
	5/32 (4.0)	WL2532X7		5/32 (4.0)	—

Replacement Parts

Torch Bodies

W-250	WP-20
W-250 Valve	WP-20V

Handles

W-250 (ribbed)	53N06R
W-250 Valve (knurled)	53N06

Valve Knob

W-250 Valve	VS-2
-------------	-------------

Braided Rubber Power Cables and Hoses

	12.5 ft. (3.8 m)	25 ft. (7.6 m)
Power Cable	45V03R	45V04R
Water Hose*	45V07R	45V08R
Gas Hose*	45V09R	45V10R

Vinyl Power Cables and Hoses

	12.5 ft. (3.8 m)	25 ft. (7.6 m)
Power Cable	45V03HD	45V04HD
Water Hose*	45V07HD	45V08HD
Gas Hose*	45V09	45V10

*Requires hose clamp 53N04.

Genuine Miller® Accessories



Accessory Kit **AK4C**

Includes one long back cap, one of each size (#5, #6, #7) alumina nozzle, and one of each size (1/16, 3/32, 1/8 inch) of the following: collet, collet body, and 7-inch 2% ceriated tungsten electrode.

Extension Kit

EK-1-25-R 25 ft. (7.6 m), rubber



Cable Covers

WC-3-10
10 ft. (3 m)
WC-3-22
22 ft. (6.7 m)



Wireless Remote Foot Control **300429**

For remote current and contactor control. Receiver plugs directly into the

14-pin receptacle of Miller machine. 90-foot (27.4 m) operating range.



Wireless Remote Hand Control **300430**

For remote current and contactor control. Receiver plugs directly into the 14-pin receptacle of Miller machine.

300-foot (91.4 m) operating range.



RCC-14 Remote Contactor and Current Control **151086**

East/west rotary-motion fingertip control attaches to TIG torch using two hook-and-loop fasteners. Includes 26.5-foot (8 m) cord with 14-pin plug.



RCCS-14 Remote Contactor and Current Control **043688**

North/south rotary-motion fingertip control attaches to TIG torch using two hook-and-loop fasteners. Includes 26.5-foot (8 m) cord with 14-pin plug.



Low-Conductivity TIG Coolant **043810**

Sold in multiples of four in 1-gallon recyclable plastic bottles. Miller coolants contains a base of ethylene glycol and deionized water

to protect against freezing to -37° Fahrenheit (-38°C) or boiling to 227° Fahrenheit (108°C).

Distributed by:

